

SAKAI

Vibratory Soil Compactors

SV201 Series

- Trench Compaction, Confined Areas
- Low/Medium Site Prep and Utility Work
- Highest Applied Force In Its Class
- Up To 59% Gradability
- Unique, Heavy-Duty Hitch Design
- Superior Steering Articulation/Oscillation
- Exceptional Stability
- Most Advanced Shock Isolation System



The Sakai SV201 Series are designed for low to medium production on a variety of soil compaction jobs – trenches, site preparation and utility work. With a minimal side overhang and high ground clearance on both sides, these compactors are ideal for tight spots. Sakai offers the SV201 Series in four different models to meet the challenges presented by different soil types.

SV201D – Provides a smooth drum with drum and axle drive for use on sand, gravel and semi-cohesive soils.

SV201T – Provides a padfoot drum with drum and axle drive for use on clays, silts and cohesive soils.

SV201TB – Adds a strike-off blade to the padfoot drum model for backfilling and leveling applications.

SV201TF – Provides a bolt-on smooth drum shell that mounts over the padfoot drum for quick drum switches on applications where soil conditions vary.

Powerful Performance

- **High Compaction Force** – The SV201 Series are designed to meet high density requirements over a wide range of soils and lift thicknesses. With a high nominal amplitude and over 20,000 pounds of applied force, the Sakai SV201 Series provide the highest applied force over any competitive models. All SV201 models offer 16,100 pounds of centrifugal force over the 54" wide drum – ensuring rapid compaction of virtually any soil type.

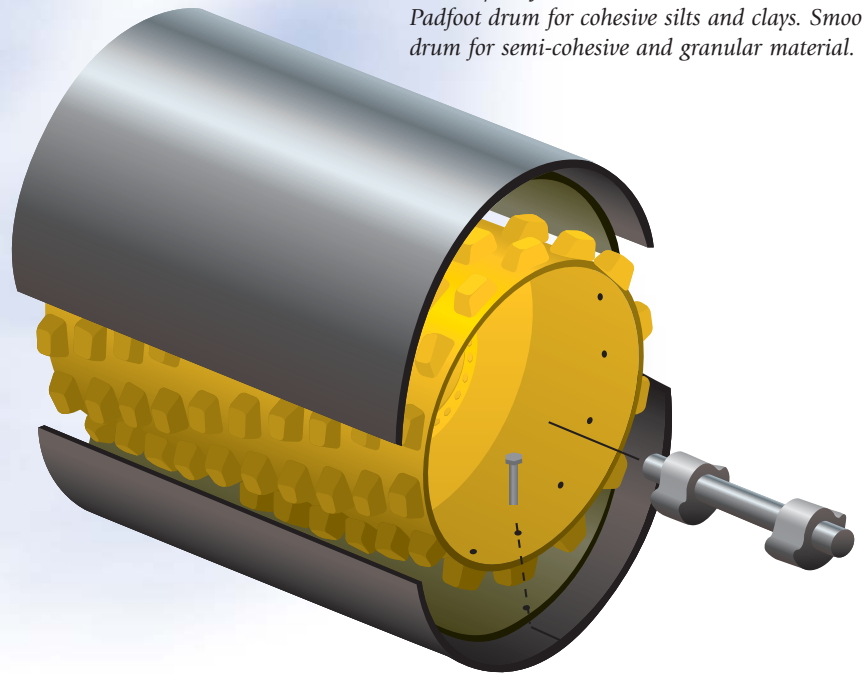
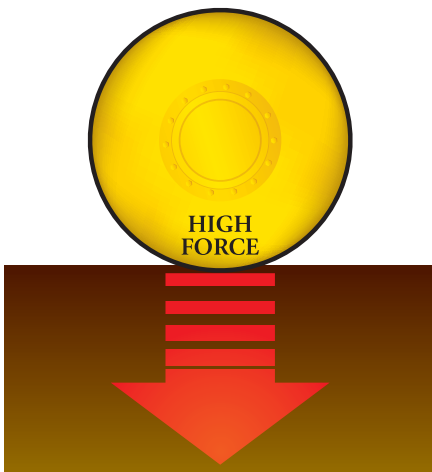

Smooth/Padfoot Combination Drum – Padfoot drum for cohesive silts and clays. Smooth drum for semi-cohesive and granular material.

- **Long-Life Vibration System** – The Sakai SV201 Series hydrostatic vibration system consists of few moving parts – a pump, a control valve, and a hydraulic motor – so it is designed for long life and easy maintenance. The hydraulic motor directly drives the eccentric shaft vibrator, and the vibrator bearings are automatically lubricated by an oil bath when the machine is in motion – making this system very low maintenance.

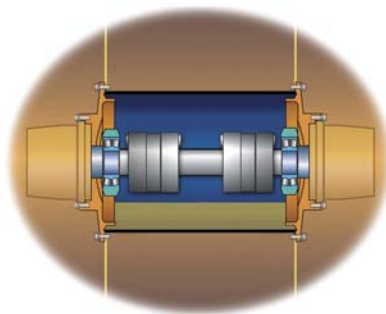

- **Superior Traction** – The SV201 Series are propelled by both the drum and the axle. In addition, a traction valve regulates power between the two drives – giving these machines superior traction on hills, slippery surfaces and grades up to 59%. The no-spin differential and a single lever speed control further assure smooth propulsion on rough surfaces. The drum drive feature also serves to pull

material beneath the drum – eliminating bow wave build up while promoting compaction.

- **Smooth/Padfoot Combination Drum** – The SV201TF model offers a quick change, dual purpose drum. Sakai takes its padfoot drum and adds a smooth drum shell – adding only 1-1/2" to the drum diameter. Competitors' "convertible" drums – which add a 4" to 6" padfoot shell to a smooth drum – dramatically change the geometry between the vibrating drum and the rear wheels, causing traction problems. Better still, the Sakai conversion does not require any modification of the hydraulic system and can be done on the jobsite in less than two hours.

- **Efficient Engine** – A highly efficient, 60 hp Cummins liquid-cooled diesel engine provides optimum power with fuel efficiency while meeting current environmental regulations. Since the SV201 Series is designed for trench work, the exhaust pipe extends upward to safely carry exhaust fumes away from the operator.

Heavy-Duty Components

- **Unique Hitch Design** – All Sakai vibratory compactors feature a unique heavy-duty hitch design. This design is much stronger than competitive

models and provides unmatched chassis stability, a $\pm 40^\circ$ articulation angle and a $\pm 10^\circ$ oscillation angle –

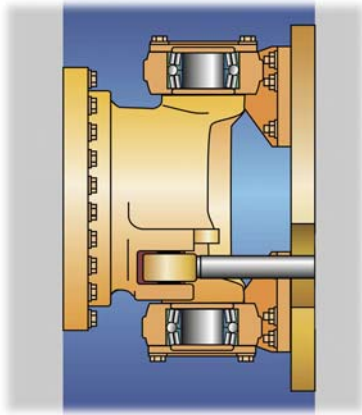

keeping the drum and wheels in contact with the ground over the roughest terrain. As a bonus, the operator benefits by smoother steering, control and comfort.

- Patented Shock Isolation –** Sakai is well known for its patented shock isolation systems. These custom designed shock isolators are better designed and stronger than any on the market today. Located between the chassis frame and the drum drive motor, the shock isolators reduce the transmission of vibration back to critical machine

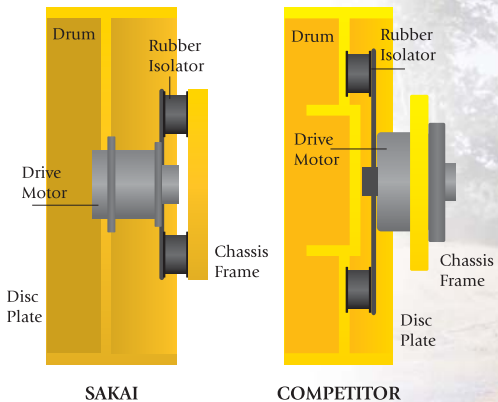

components as well as the operator. Competitive machines place the shock isolators between the drum and the drive motor – meaning these isolators wear out faster, cause the machine to jerk with each change of direction and produce a rough surface.

High Safety Standards

- ROPS and Seat Belts –** Sakai believes that operator safety is our

first priority. ROPS and seatbelts are standard equipment on every Sakai roller sold in North America.

- Failsafe Braking System –** The SV201 Series is equipped with a two brake, three-way failsafe system. A hydrostatic service brake is located at the forward-reverse lever. A wet disc, spring-applied, hydraulically-released (SAHR) parking brake switch is located on the instrument panel. An emergency brake foot pedal activates both the hydrostatic and the SAHR brakes.



Operator Comfort

The SV201 Series operator's station is a rubber isolated floating deck designed to minimize the transmission of vibration to the operator and is accessible from both sides of the machine. All instrumentation and controls are conveniently located and within easy visibility of the

operator. The machines also provide exceptional side clearances in confined spaces and 360° visibility from the operator's seat.

Superior Serviceability – Fast Support

The SV201 Series provides a fully opening engine hood for easy access to engine and hydraulic components. Large ball bearings and taper bearings in the center hitch as well as oil bath lubrication for the vibrator and vibration bearings extend lubrication intervals to 250 hours.

Sakai has been building high quality construction equipment since 1918. We manufacture more vibratory compactors annually than anyone else in the world. Sakai stocks component parts for all its products and if necessary, are available via overnight dispatch from its North American headquarters in Georgia. Call 800-323-0535 for prompt assistance with all your needs.



Model	SV201D		SV201T		SV201TB		SV201TF			
	Smooth		Padfoot		Padfoot/Blade		Combi			
Operating Weight	lbs	kg	9,590	4,350	9,810	4,450	10,470	4,750	11,465	5,200
On front	4,740	2,150	4,960	2,250	5,730	2,600	6,615	3,000		
On rear	4,850	2,200	4,850	2,200	4,740	2,150	4,850	2,200		
Vibration Frequency	vpm	Hz	1800		30					
Centrifugal Force	lbs	kN	16,100		72					
Total Applied Force	lbs	kN	20,840	93	21,060	94	21,830	97	22,715	101
Amplitude	in	mm	0.065	1.65	0.060	1.52	0.060	1.52	0.065	1.65
Engine – Model	Cummins B3.3-C									
Engine Type	Water-cooled diesel									
Horsepower	hp	kW	60		45					
	rpm	min ⁻¹	2,200		2,200					
Speeds	mph	km/h	0-4.6	0-7.4	0-4.7	0-7.6	0-4.7	0-7.6	0-4.7	0-7.6
Gradability	%		59		55		55		44	
Fuel Tank Capacity	gal	L	26		98.4					
Tire Size			11.2-24-6 PR		11.2-20-6 PR		11.2-20-6 PR		11.2-24-6 PR	
Braking	Hydrostatic, Wet Disc SAHR, Footbrake									
Steering	Articulated with heavy-duty hitch									
Dimensional Data	ins	mm	40	1,015	41.3	1,050	41.3	1,050	43	1,090
Drum Diameter (A)	54	1,370	54	1,370	54	1,370	54	1,370	54	1,370
Drum Width (B)	166	4,215	166	4,215	188	4,775 with blade	170	4,320	170	4,320
Overall Length (C)	60	1,525	60	1,525	60	1,525	60	1,525	60	1,525
Overall Width (D)	107	2,720	107	2,720	107	2,720	107	2,720	107	2,720
Overall Height (E)	92	2,340	92	2,340	92	2,340	92	2,340	92	2,340
Wheelbase (F)	11.8	300	12.4	315	12.4	315	12.4	315	13	330
Curb Clearance (G)	3	75	3	75	3	75	3	75	3	75
Side Overhang (H)	157	3,990	157	3,990	157	3,990	157	3,990	157	3,990
Outside Turning Radius	ins	mm	157		3,990		157		3,990	
Options	Lights									

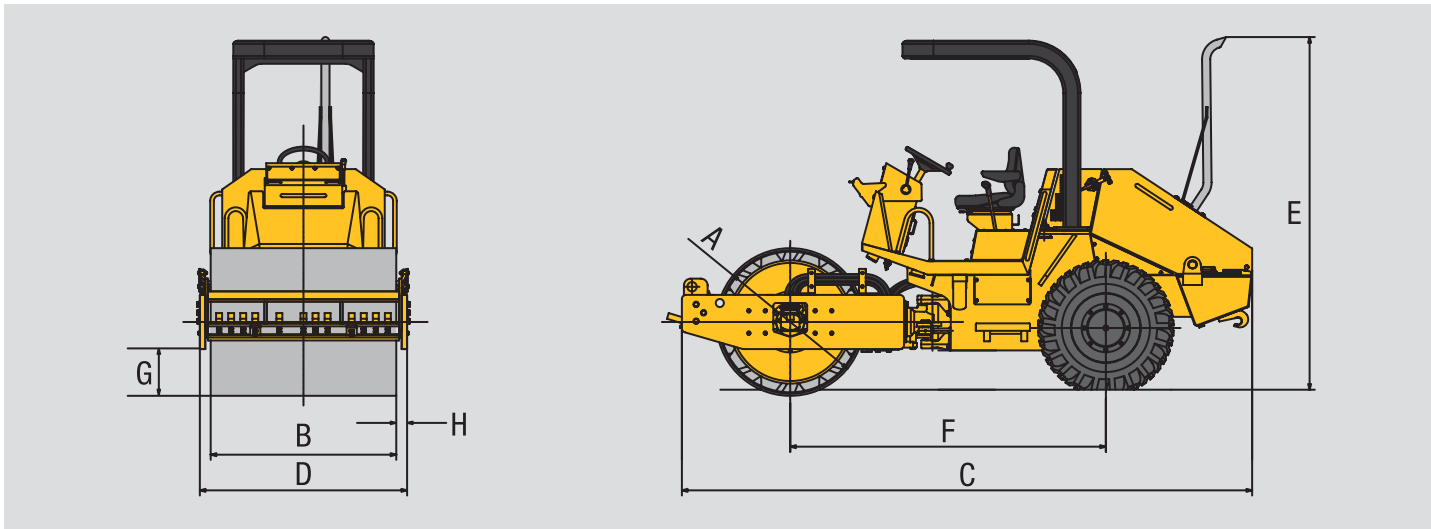

Your authorized Sakai dealer:

Sakai America Inc.
 90 International Parkway, Adairsville, GA 30103
 Tel 770-877-9433 or toll free 800-323-0535
 Fax 770-877-9886 • www.sakaiamerica.com

SV201BROC1106

