

SW800-II and SW850-II High Frequency Vibratory Rollers

SAKAI

MODEL		SW800-II	SW850-II
Operating Weight	lbs	24,030	29,030
	kg	10,900	13,070
On Front Drum	lbs	11,575	13,975
	kg	5,250	6,340
On Rear Drum	lbs	12,455	15,055
	kg	5,650	6,830
Minimum Vibration Frequency	VPM	2,500	2,500
	Hz	42	42
Maximum Vibration Frequency	VPM	4,000	4,000
	Hz	67	67
Centrifugal Force-lo	lbs	10,580	13,010
	kN	47	58
Centrifugal Force-hi	lbs	27,120	33,290
	kN	121	148
Lo Amplitude	inches	0.013	0.013
	mm	0.33	0.33
Hi Amplitude	inches	0.022	0.022
	mm	0.55	0.55
Engine Make & Model		Deutz TCD2012L04-2V	Deutz TCD2012L04-2V
Horsepower		hp / kW	127 / 95
Maximum Speed		mph / kmh	7.8 / 12.5
Gradability		percent	33
Fuel Tank Capacity		gallons / liters	58 / 220
Spray System Capacity		gallons / liters	264 / 1,000
Brake Types		Hydrostatic Service Brake + SAHR+Combined Footbrake	Hydrostatic Service Brake +SAHR+Combined Footbrake
Steering Types		Articulated	Articulated
Articulation Angle		degrees	35
Outside Turning Radius		inches / mm	235 / 6,020
Inside Turning Radius		inches / mm	170 / 4,318
Oscillation Angle		degrees	7
DIMENSIONAL DATA			
Drum Diameter A		inches / mm	51 / 1,300
Drum Width B		inches / mm	67 / 1,700
Overall Length C		inches / mm	221 / 5,620
Overall Width D		inches / mm	75 / 1,905
Overall Height E		inches / mm	126 / 3,210
Wheelbase F		inches / mm	130 / 3,300
Curb Clearance G		inches / mm	19.5 / 500
Side Overhang H		inches / mm	4 / 101

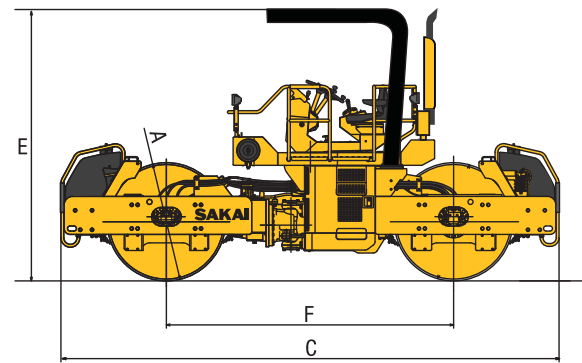
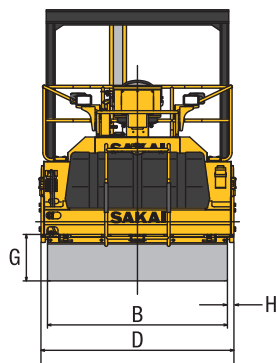

Your authorized Sakai dealer:

SAKAI

MASTERS OF COMPACTION

Sakai America Inc.
90 International Parkway, Adairsville, GA 30103
Tel 770-877-9433 or toll free 800-323-0535
Fax 770-877-9886 • www.sakaiamerica.com

SW800-II BROC409



Two High Frequency Asphalt Rollers

For County, State and Interstate Highways
and Airport Runways

Counter-Rotating Eccentric Weights

Amplitude Controlled from Operator's
Station

Built-In ExactCompact for Precise Impact
Spacing. Optional on the SW800-II

Industry-Leading Sakai Intelligent
Compaction Available

Superior Triple-Filtered Spray Systems

High Curb Clearances

Sakai SW800-II & SW850-II

• **Compaction System** – The Sakai High Frequency Difference – Sakai offers the highest productivity of any vibratory rollers on the market. The SW800-II Series are literally the fastest rollers available – featuring a high frequency, 4,000 vpm designed to beat the tender zone on Superpave and other perpetual pavement mixes. The SW800-II Series eccentric weights rotate faster – permitting faster ground speeds while maintaining the customary 10-12 impacts per foot at 4.55 mph.

These rollers are engineered from the ground up to produce a true 4,000 vpm – not like competitors' attempts to get faster compaction at the expense of the machines and components. The SW800-II Series are also extremely versatile – offering dual amplitude and three frequencies – all easily switched at the operator's station and while the roller is in motion. Plus, smooth machined drums, excellent drum edge visibility, and high curb clearances all ensure superior finishes regardless of the mix or application.



SW800-II

SW800-II – Provides a dual drum drive system that eliminates bow wave build-up in the front of the machine.



SW850-II

SW850-II – Provides smooth machined drums and rounded edges for a smooth mat surface.

• **Unique Eccentric Weight Design** – All Sakai vibratory compactors offer our unique eccentric weight design. In addition to rotating the weights faster, Sakai eccentric weights spin in a counter-rotational direction – the front drum clockwise and rear drum counter-clockwise, or vice versa. This feature directs the forces downward into the material, eliminating the possibility of pavement shoving, scuffing and hairline cracks.

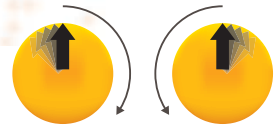

Sakai Counter-Rotating Weights

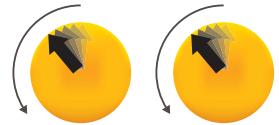

Competitive Unidirectional Weights

• **ExactCompact** – A new on-board feature called ExactCompact – an impact space indicator and speed meter – enables the operator to determine optimum settings on a test strip and then program the settings into the roller. A series of yellow, red and green lights permit the operator to adjust the ground speed to match the lights. This enables a quick and accurate adjustment without the need for a frequency meter or additional ground labor. Standard on the SW850-II roller. Optional on SW800-II.



• **Traction** – The SW800-II Series rollers offer dual drum drive to ensure excellent traction and eliminate bow wave build-up in front of the machine. The drum drive system is completely independent from the vibration system – ensuring that the vibration frequency is maintained. The drum drive and vibration motors are cross-mounted between the front and rear drums, balancing the weight from front to rear as well as left to right – and keeping the machines rolling straight even at slower speeds.

• **Efficient Engine** – The SW800-II Series rollers are powered by low noise, fuel-efficient, water-cooled, turbo-charged Deutz diesel engines. These engines fully comply with current EPA/CARB emission standards. The engines are mounted on rubber isolators to absorb vibration. The engine doors are noise-suppressed and fully open for safe, simple maintenance from the ground level.

Operator Comfort

The SW800-II Series operator's station is a rubber-isolated floating deck designed to minimize the transmission of vibration to the operator and to reduce fatigue. Accessible from both sides of the machine, the operator's station consists of a five-position, 180° rotating console where the instrument panel rotates with the seat – ensuring that all controls are conveniently located and within easy reach and view of the operator. The machines also provide minimal side clearances and 360° visibility of the drum edges, drum surfaces, and pavement joint area from the operator's seat.

• **Unique Hitch Design** – All Sakai vibratory compactors feature a unique heavy-duty hitch design that is stronger than competitive models. This joint system provides unmatched chassis stability with superior horizontal articulated steering and vertical oscillation for superb ground contact on all surfaces. This system, combined with hydraulically powered steering, gives the operator better control and smoother steering. Lubrication service intervals are only required every 250 hours vs. competitive models that require daily service.

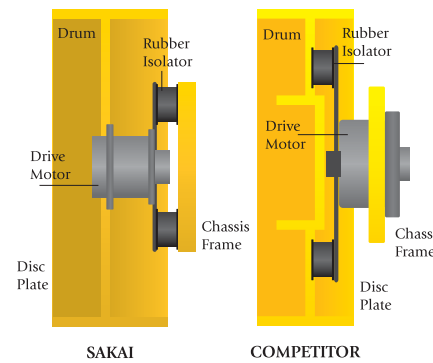

Heavy-Duty Components

• **Patented Shock Isolation** – Despite powerful vibration, the machine chassis and operator are fully protected by the Sakai patented shock isolation system – the most effective on the market today. The rubber isolators are completely independent of the drum drive system. Located between the chassis frame and the drum drive motor, the shock isolators reduce the transmission of vibration back to critical machine components as well as to the operator.

Competitive machines place the shock isolators between the drum and the drive motor – meaning these isolators wear out faster because the drive torque is transferred to the drum through the rubber isolators – whether the vibration system is on or off. This wear then causes the machine to jerk with changes in direction. This irregular movement can cause pushing/pulling of the asphalt material, rough surfaces or hairline cracks in the pavement.

Other features of the SW800-II Series include smooth machined drums, excellent drum edge visibility and a high curb clearance to avoid guard rails and concrete barriers.

High Safety Standards

• **ROPS and Seat Belts** – Sakai believes that operator safety is a high priority. ROPS and seat belts are standard equipment on every Sakai roller sold in North America.

• **Failsafe Braking System** – The SW800-II Series are equipped with a two-brake, three-way failsafe system. A hydrostatic service brake control is located at the forward-reverse lever. A wet disc, spring-applied, hydraulically-released (SAHR) parking brake switch is located on the instrument panel. An emergency brake foot pedal activates both the hydrostatic and the SAHR brakes. SAHR braking will automatically apply in the event of an engine or hydraulic system failure.

Superior Serviceability- Fast Support

Sakai has been building high quality construction equipment since 1918. We manufacture more vibratory compactors annually than anyone else in the world. Sakai stocks component parts for all its products and if necessary, these are available via overnight dispatch from their North American headquarters in Georgia. Call your authorized Sakai dealer or Sakai directly at (800) 323-0535 for prompt application and service needs.

